

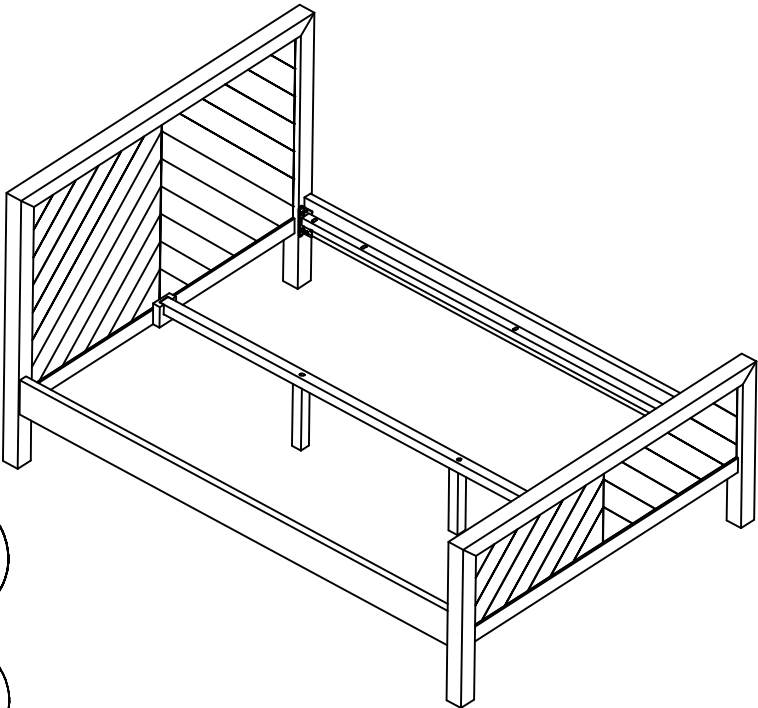

SMALL DOUBLE(Solid slats)
(Sprung slats)
DOUBLE (Solid slats)
 (Sprung slats)
KING (Solid slats)
(Sprung slats)

LEIGHTON BED

ASSEMBLY INSTRUCTION



Minimum No.of people recommended to assemble this product

2

Approx assembly time

45
minutes



Before you start, here is some helpful advice

1. We suggest you spend a short time reading through this leaflet and then follow the simple step by step instructions.
2. If you follow the instructions carefully the end result should be worth the effort.
3. Do not discard any of the packaging until you have checked that you have all the parts and the pack of fittings.
4. To ensure an easier assembly, we strongly advise that all fittings are only finger tightened during initial assembly. Only upon completion of the Assembly should all fixing points be fully tightened.
5. We recommend a periodic check on all fixing points to make sure they remain fully tightened.
6. Keep glue and fittings out of children’s reach.
7. In the unlikely event that this product has missing or damaged parts, please call 0844 292 0000 to obtain spares

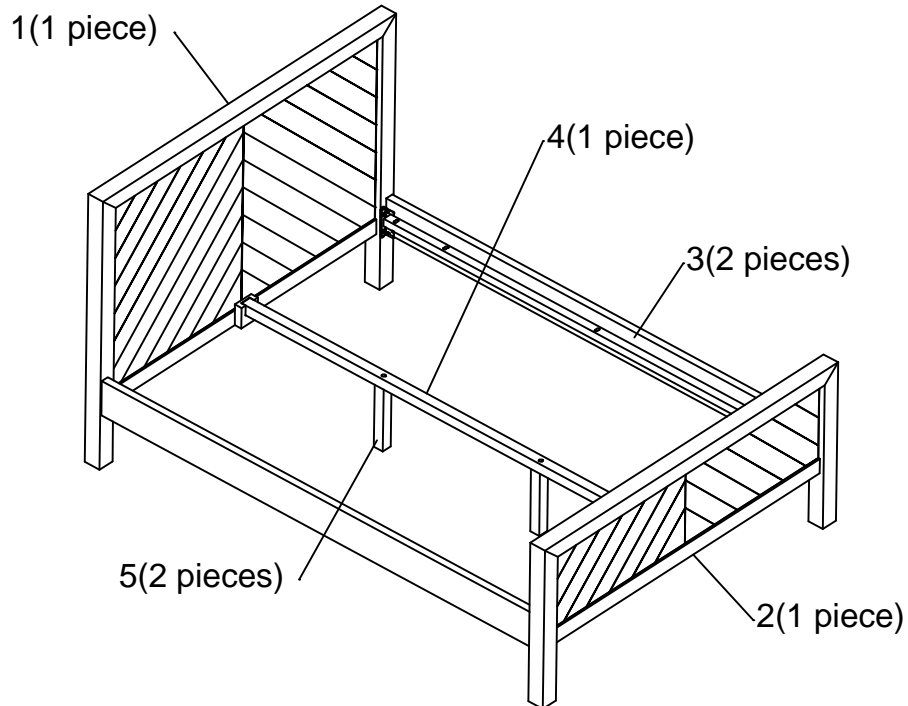

PARTS

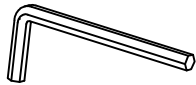

FITTINGS

<p>A</p>  <p>M6 x 45mm x 8pcs.</p>	<p>B</p>  <p>M6 x 20mm x 6pcs.</p>	<p>C</p>  <p>Flat washer Ø19 x 8pcs</p>
<p>D</p>  <p>Allen key 4mm x 2pcs.</p>		

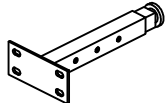
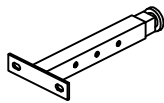
Note: The following fittings will be found in the box which contains the Sprung Frame, NOT with the bed frames Assembly Kit.

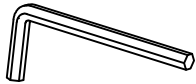
<p>E</p>  <p>Center leg x 1pc.</p>	<p>F</p>  <p>Center leg x 2pcs.</p>	<p>G</p>  <p>M6 x 12mm x 8pcs.</p>
<p>D</p>  <p>Allen key 4mm x 1pc.</p>		

Assembly **ASSEMBLY**

LEIGHTON BED

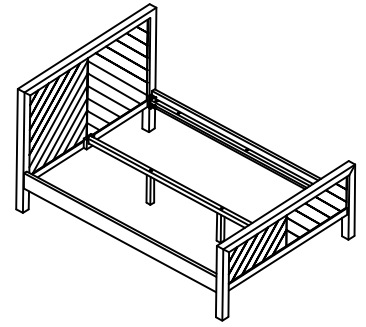

Fix the side rails "3" to the headboard "1" and footboard "2".

Tighten the bolts which are pre-fitted on Head & Foot End using allen key "D".

STEP 1

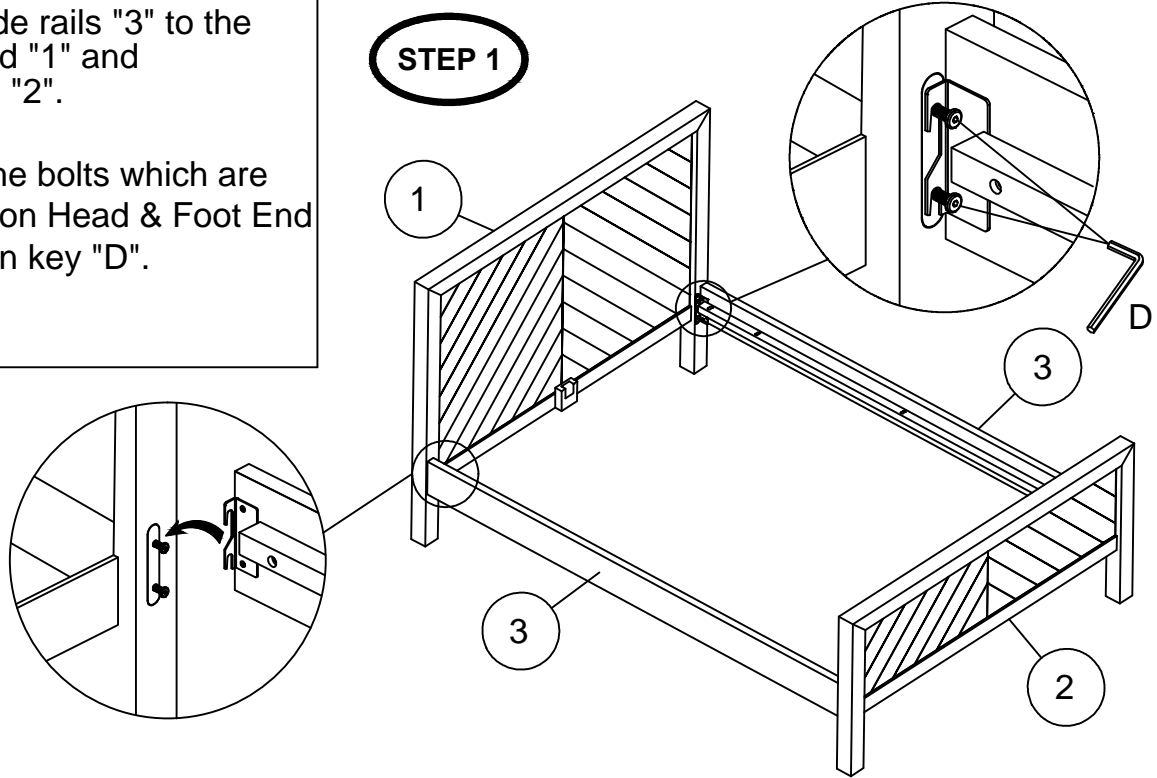

! Identify the slat system you have purchased...

Standard wooden slat system

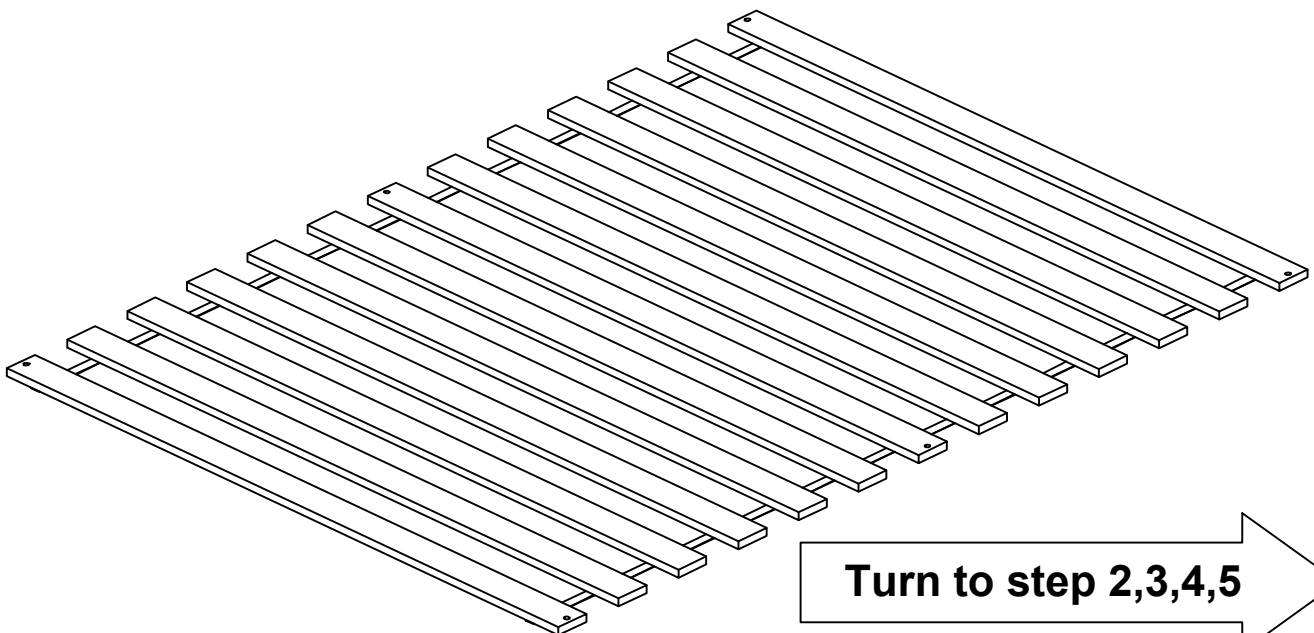

Turn to step 2,3,4,5

Sprung slat system

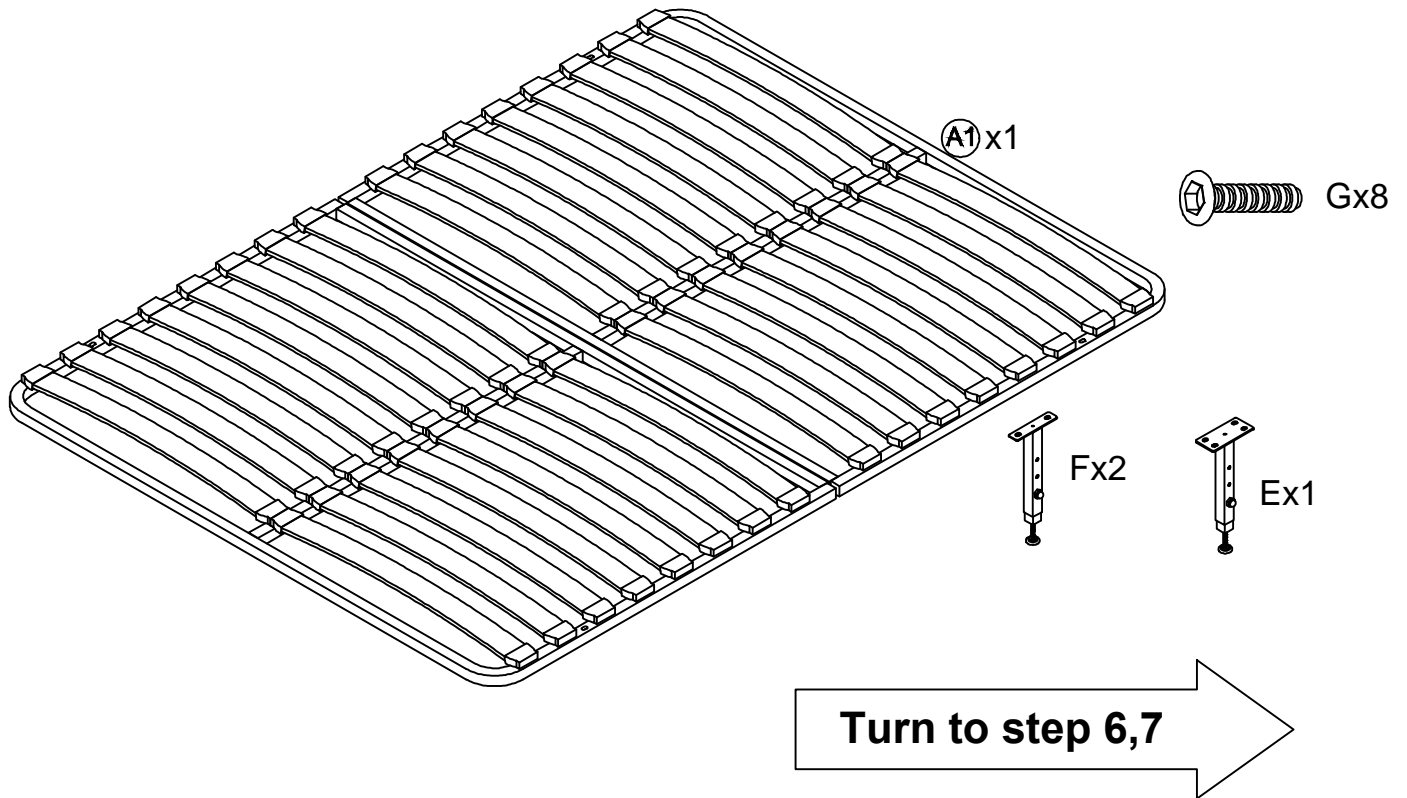

Attach central support "4" to support feet "5".

Use bolts "A" and flat washers "C", tighten using allen key "D".

STEP 2

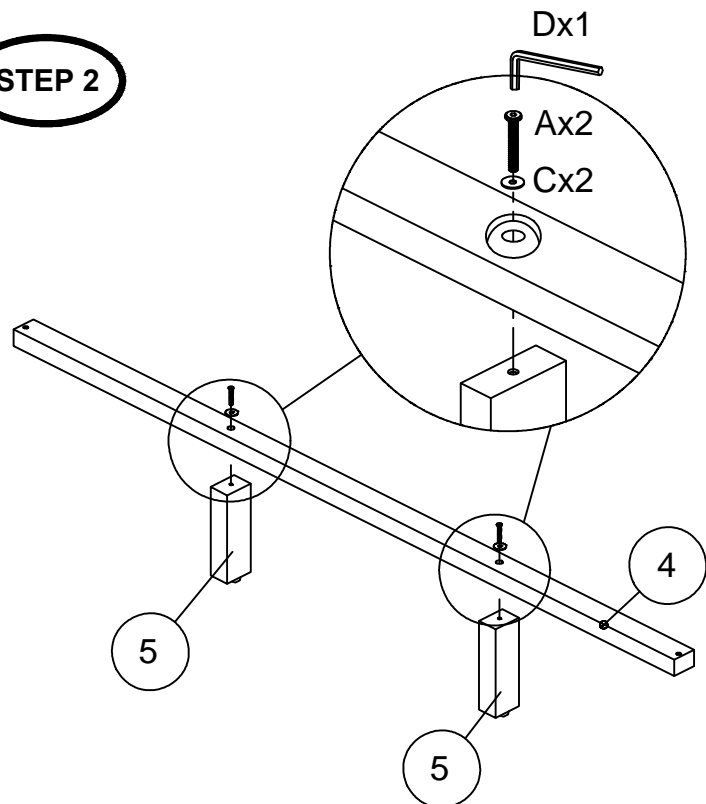

Place the fixed central support "4" onto the support block on headboard "1" and footboard "2".

STEP 3

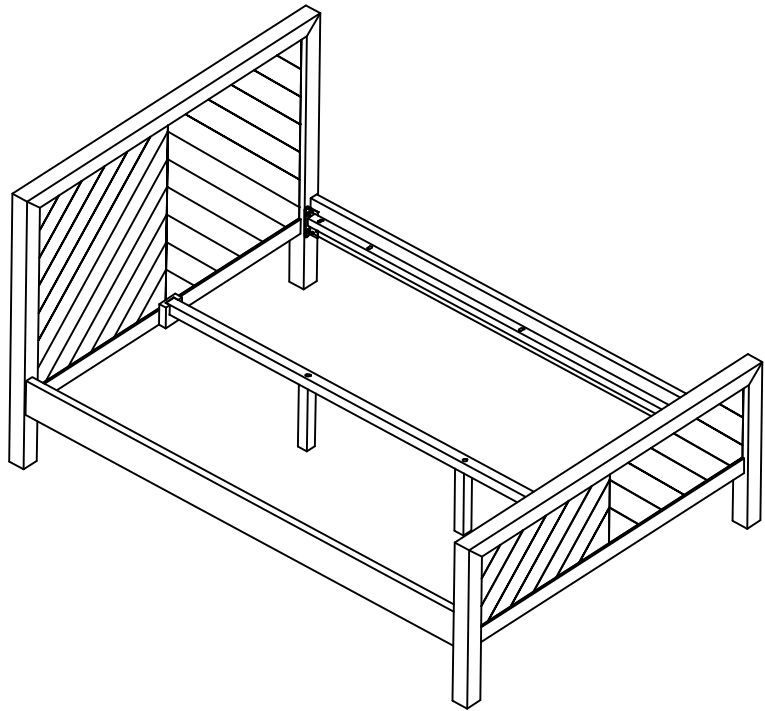

IMPORTANT

Once the feet have been assembled and attached, they should be adjusted to ensure they do not touch the floor, (10mm above the floor) to allow for movement once the mattress is placed on the bed frame.

It is important to note that when moving the bed that it is not dragged into its new position to prevent the possibility of these feet being twisted or angled to one side, which could lead to the collapse of the centre of the bed.

To move the bed, remove the mattress and lift the bed into its new position to avoid damage.

Ensure the feet are at 90° to the floor before replacing the mattress.

STEP 4

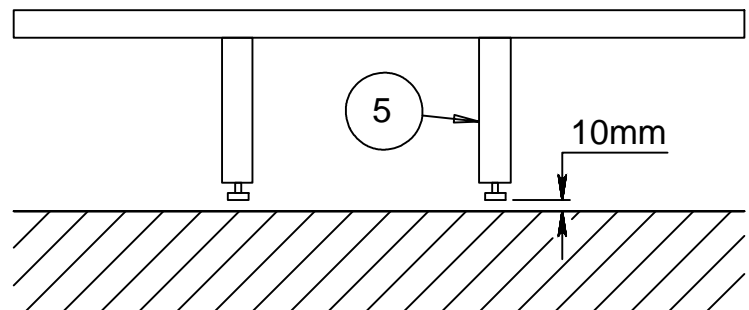

Standard wooden slat system

STEP 5

Place the fixed wood slats onto the slat holders on side rails "3".

Fix the slats at both ends and the middle using bolts "A", sleeve nuts "B" and flat washers "C", tighten with allen key "D".

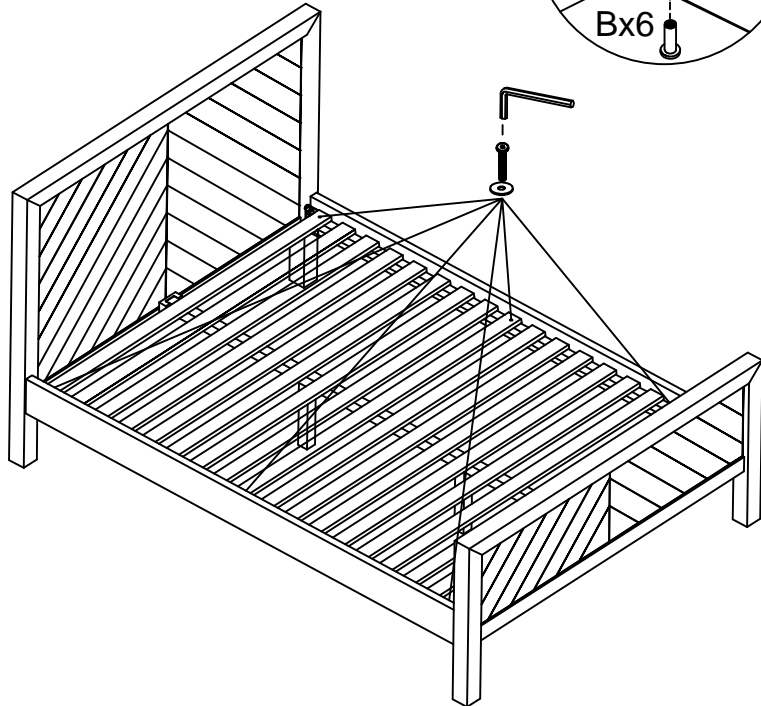
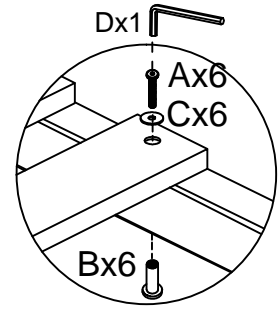

Sprung slat system

STEP 6

Fix the center legs to the frame

Use bolts "G", tighten using allen key "D".

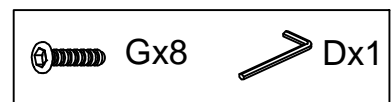
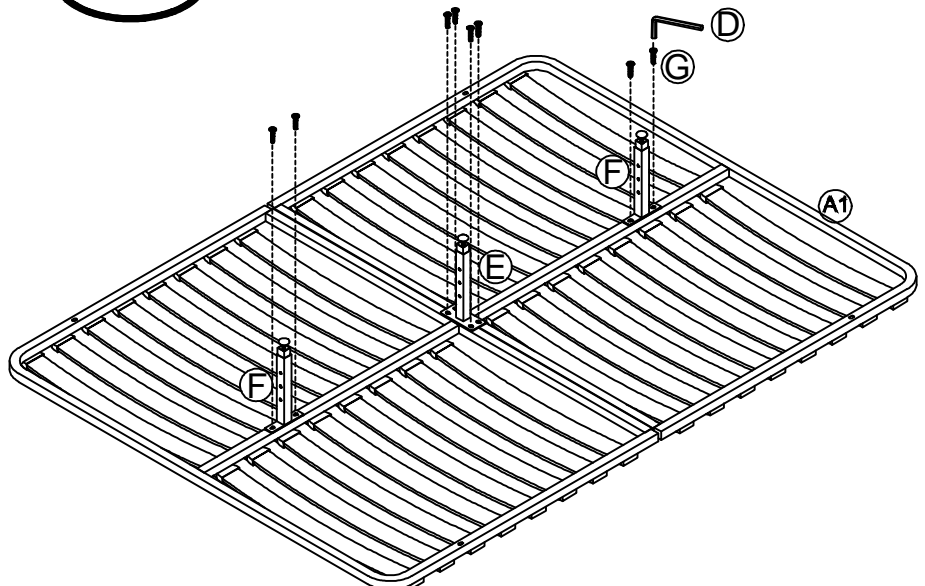

Adjust leg height to suit bed frame

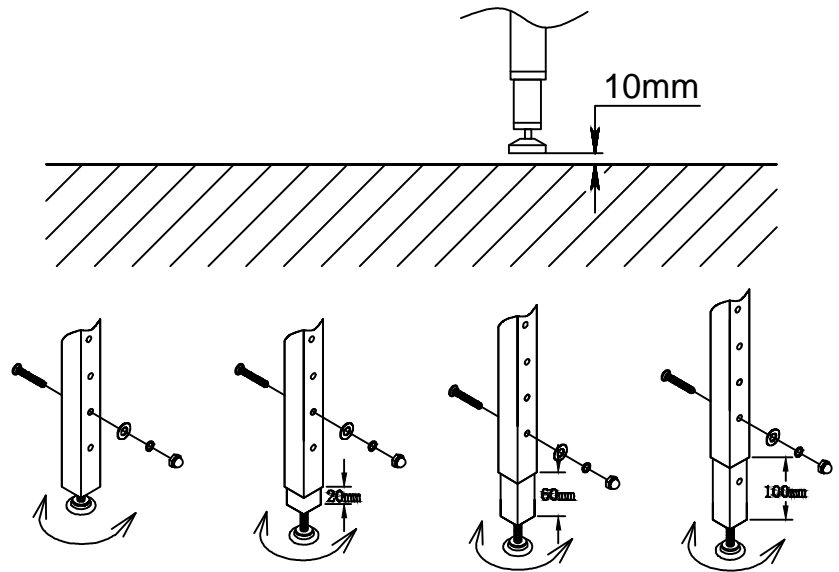

Please note: the center bar "4" and wooden support feet "5" can be probably disposed if choosing sprung slat frame

Turn the metal slat frame falling upward and carefully lower the slat frame into the bed.

Ensure that the frame sits on the guides located on the side rails "3".

Position the slat frame so that the holes in the frame align with those in the side rails "3".

Secure the frame to the side rails "3" by threading bolt "A" through the holes in the frame and the side rails "3".

Finally, tighten the bolt "A" into the sleeve nut "C" from the top of slats frame with with allen keys "D".

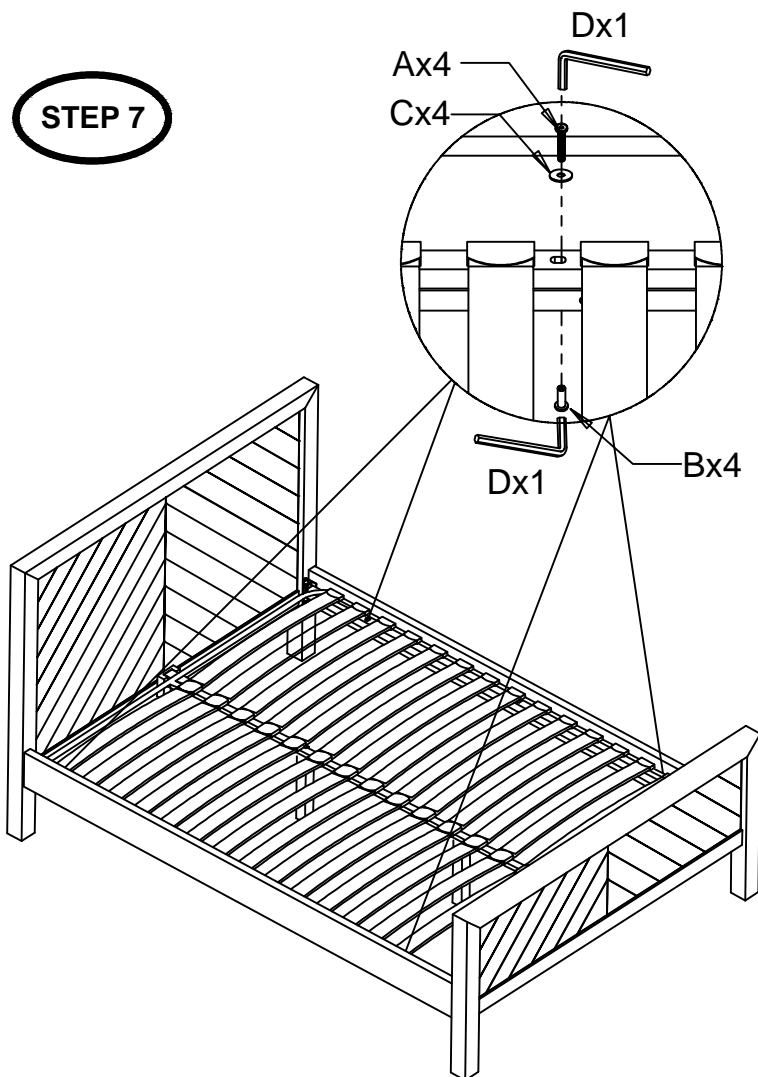

STEP 7