

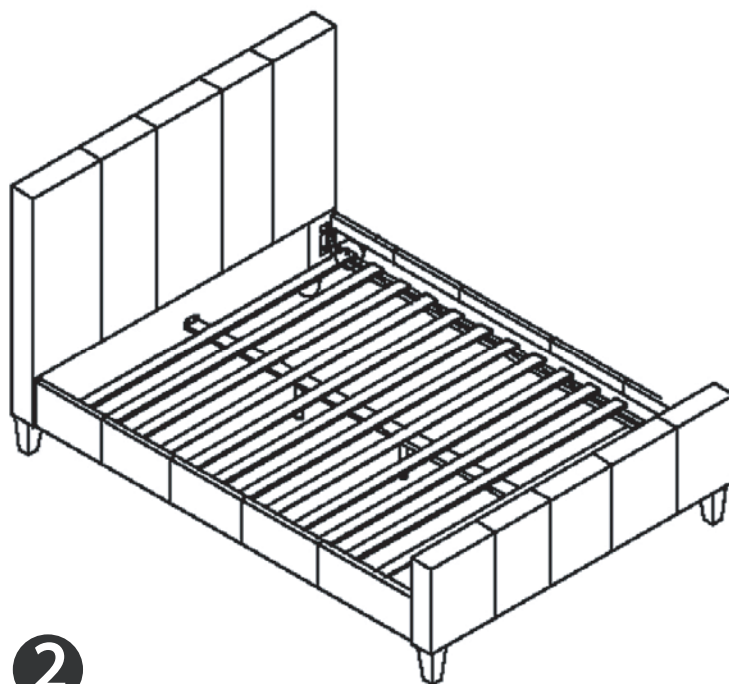

# Giovanni (DOUBLE, KING SIZE AND SUPERKING) Assembly Instructions



Minimum No. of people recommended to assemble this product:

2

Approx assembly time:







1/2 hour

## Before you start, here is some helpful advice

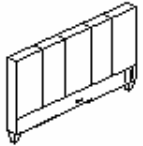
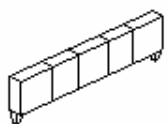
1. We suggest you spend a short time reading through this leaflet and then follow the simple step by step instructions.
2. If you follow the instructions carefully the end result should be worth the effort.
3. Do not discard any of the packaging until you have checked that you have all the parts and the pack of fittings.
4. Assemble this product on a carpet.
5. To ensure an easier assembly, we strongly advise that all fittings are only finger tightened during initial assembly. Only upon completion of the. Assembly should all fixing points be fully tightened.
6. We recommend a periodic check on all fixing points to make sure they remain fully tightened.
7. Keep any fittings out of children's reach.

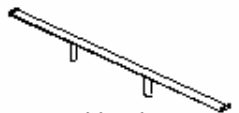
In the unlikely event that this product has missing or damaged parts, please call 0870 3333 612 to obtain spares.

# Component parts and fittings contained in the box

 <p>① Headboard (1 pc)</p>	 <p>② Footboard (1 pc)</p>	 <p>③ Side Rails (2 pcs)</p>	 <p>④ Wooden slat base (1 pc)</p>
 <p>⑤ Centre Rail (1 pc)</p>	 <p>⑥ Screws (6 pcs)</p>	 <p>⑦ Round Head Bolts (2 pcs)</p>	 <p>⑧ Bracket (2 pcs)</p>

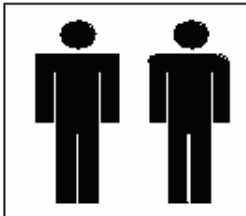

**TWO PEOPLE NEEDED TO ASSEMBLE THIS BED**

## ASSEMBLY

STEP 1

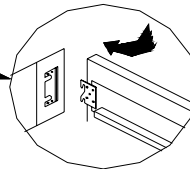
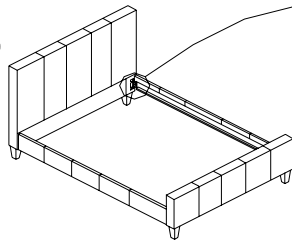

INSERT 1

Slide the hooks on the side rails (3) into the slots located on the headboard (1) and footboard (2). Press down until they click to secure (see insert 1)

STEP 2

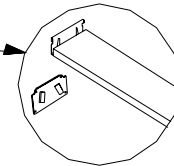
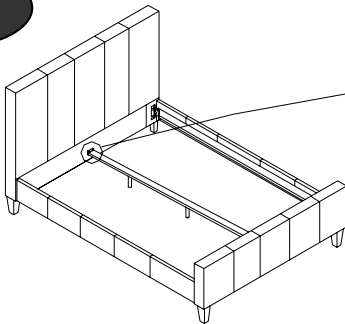

INSERT 2

Connect the brackets (8) to each end of the wooden centre rail (5), using round head bolts (7). Secure the centre rail (5) to the headboard (1) and the footboard (2) by sliding the brackets (8) onto the corresponding brackets located on the headboard and footboard (see insert 2)

# ASSEMBLY

## STEP 3

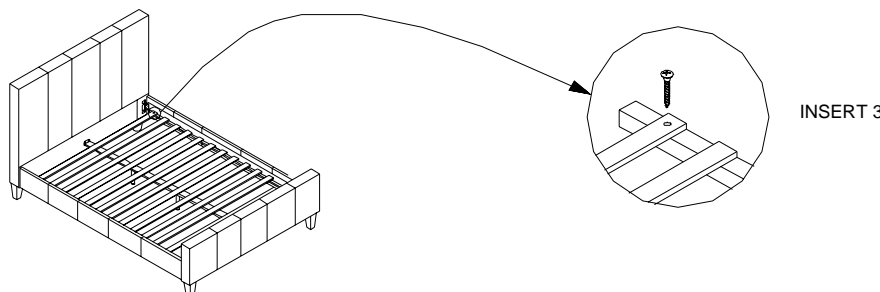

Position slats equally across the bed frame and screw securely using screws (6). (See insert 3).

# AFTER CARE

1. To clean your bed, use a soft cloth moistened in lukewarm solution of soap and water.
2. You will need to tighten the assembly screws, etc, periodically.
3. Keep away from direct sunlight.
4. Don't stand on wooden slats.